

Linear Motors

ETEL

ABOUT ETEL LINEAR MOTORS

Over the last 20 years, direct drive linear motors have provided significant performance improvements in numerous applications covering a wide range of high-tech industries. Today, direct drive technology is recognized as a leading solution towards meeting the requirements of high productivity, improved accuracy, and increased dynamics of modern machinery.

Direct drive essentially means the load and motor are directly connected; or in other words, the motor "directly drives" the load. Significant improvement to stiffness and a more compact solution are among the benefits of this technology. In addition to providing high dynamic performance, linear motors reduce cost of ownership, simplify the design of the machine and eliminate wear and maintenance.

Since its founding in 1974, ETEL has been exclusively dedicated to the development of direct drive technology. Through numerous innovations and patented designs, ETEL continues to provide unmatched force efficiency for the most optimized designs.



What is a linear motor?

Linear motors are a special class of synchronous brushless servo motors. They work like torque motors, but are opened up and rolled out flat. Through the electromagnetic interaction between a coil assembly (primary part) and a permanent magnet assembly (secondary part), the electrical energy is converted to linear mechanical energy with a high level of efficiency. Other common names for the primary component are motor, moving part, slider or glider, while the secondary part is also called magnetic way or magnet track.

Since linear motors are designed to produce high force at low speeds or even when stationary, the sizing is not based on power but purely on force, contrary to traditional drives.

The moving part of a linear motor is directly coupled to the machine load, saving space, simplifying machine design, eliminating backlash, and removing potential failure sources such as ballscrew systems, couplings, belts, or other mechanical transmissions. Finally, the bandwidth and the stiffness of the motion system are much higher, giving better positional repeatability and accuracy over unlimited travel at higher speeds.

Given that frameless linear motors do not include a housing, bearings, or feedback device, the machine builder is free to select these additional components in order to best fit the application requirements.

Linear motor advantages

Key benefits inherent to the adoption of the linear motor technology include:

- High dynamics
- High accuracy
- Optimal speed control
- Very compact design
- Outstanding MTBF
- Low maintenance

These advantages are further explained in the following pages.

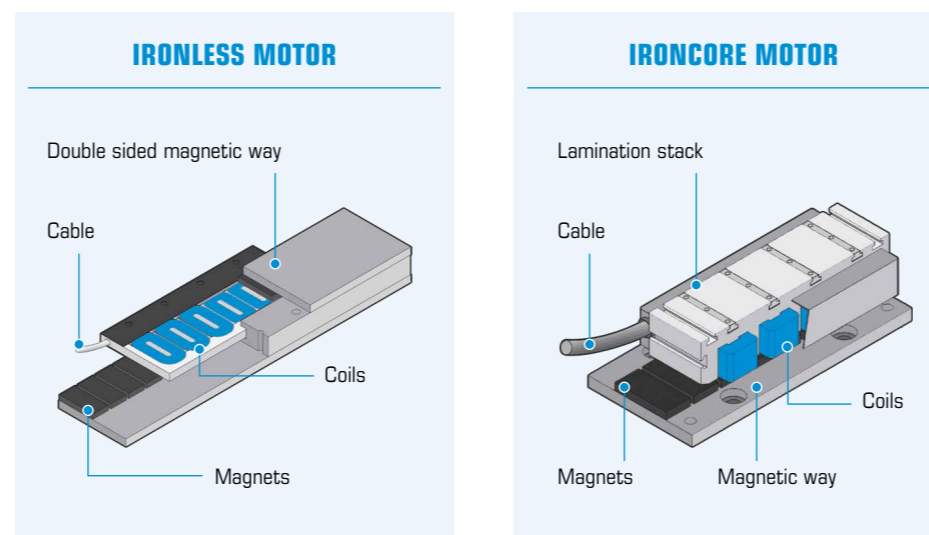

INDUSTRY SECTORS

Below are some examples of industry sectors where linear motors are successfully used, providing our customers in these areas with a distinct competitive advantage.

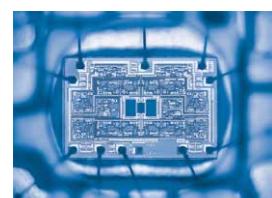

Wafer and die level packaging



Process control

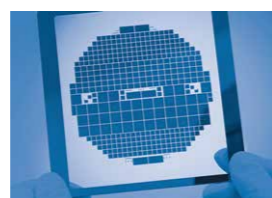

Lithography



Test and control equipment



Placement machines



Flat panel display (FPD)



Photovoltaic



Optics



Stamping / laser cutting



Medical

WHY ADOPT LINEAR MOTORS?

Reduced cost of ownership

Direct coupling of the payload to the moving part of the motor eliminates the need for mechanical transmission elements such as leadscrews, timing belts, rack and pinion, and worm gear drives. Unlike brushed motors, in a direct drive system there is no contact between the moving parts. Therefore there is no mechanical wear, resulting in excellent reliability and longevity. Fewer mechanical parts minimize maintenance and reduce the system cost. The direct drive technology results in an efficient and effective gearless assembly when deployed to complex motions systems.

Easy integration

ETEL linear motors are available in a wide range of sizes and can be easily adapted to most applications. ETEL's unmatched standard product offering includes ironless and ironcore linear motors. Each technology has specific advantages:

- Ironcore linear motors configuration minimizes the volume required for integration in machines. They are very compact and produce the greatest force per package size.
- Ironless linear motor shape is very thin and gives machine builders great flexibility in locating the motors. In addition, ironless motors provide no force ripple and have very low moving masses.

Dynamic performance

Linear motor applications have a wide range of dynamic performance requirements. Depending on the specific duty cycle of a system, the peak force and maximum speed will determine the selection of a motor:

- An application with a light payload that requires very high speed and acceleration will typically utilize an ironless linear motor (that has a very light moving part containing no iron). As they have no attraction force, ironless motors are preferred with air bearings, when the speed stability has to be below 0.1%.
- Ironcore motors produce greater force per package size by using laminations to concentrate the magnetic flux. With a larger continuous force, these motors fit very well to mid- and high-dynamic applications requiring high duty cycles.

Wide force-speed range

Direct drive linear motors deliver high force over a wide range of speeds, from a stalled or low speed condition to high velocities.

Linear motors can achieve very high velocities (up to 15 m/s) with a trade off in force for ironcore motors, as technology becomes limited by eddy current losses. Linear motors achieve very smooth velocity regulation, with low ripple. The performance of a linear motor over its velocity range can be seen in a force-speed curve as shown opposite.

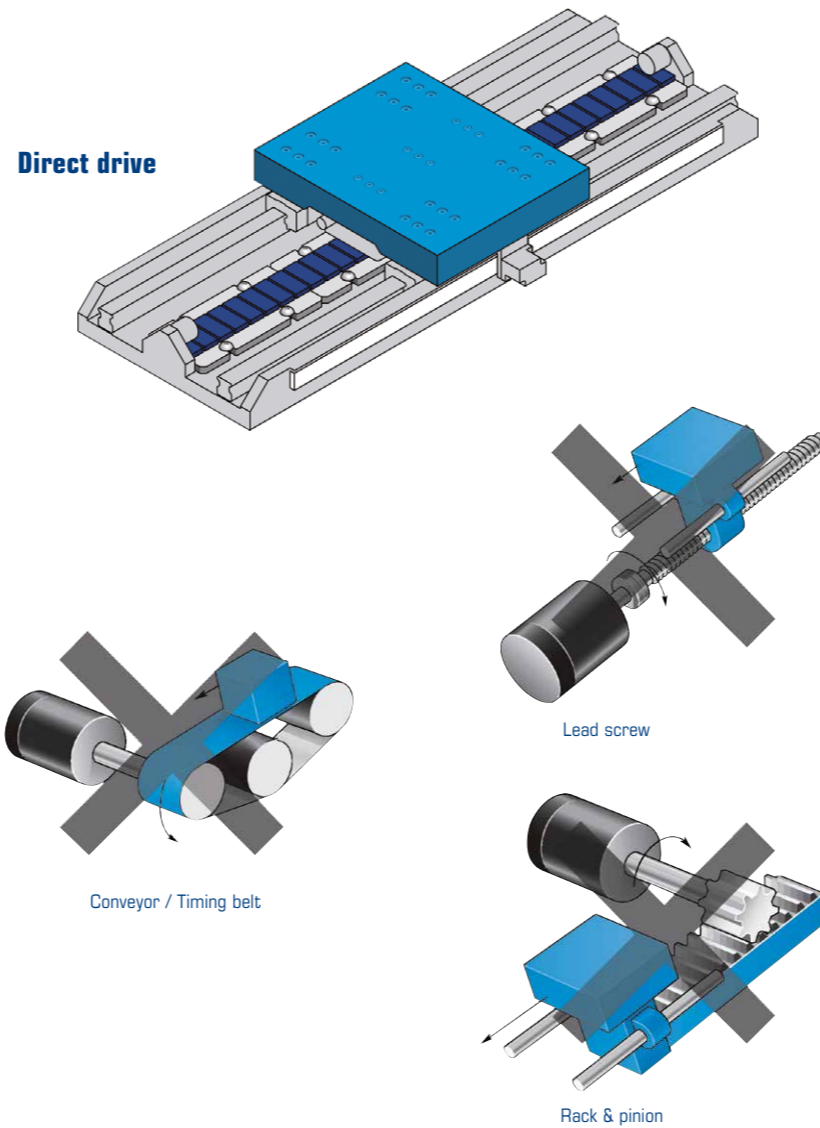

Force vs. speed for LMG10-070-3QB

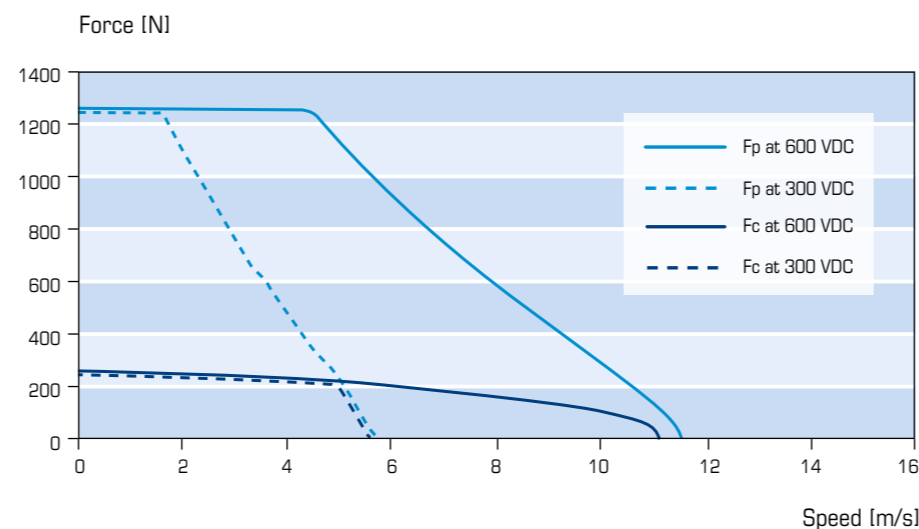

WHY CHOOSE ETEL?

Technology expertise

ETEL's know-how in ironcore design provides the industry with the most efficient direct drive linear motors. The design is especially optimized to reach high force density together with the lowest possible force ripple.

Unmatched performance

A complete direct drive solution with ETEL motion and position controllers provide optimum system performance. A full ETEL solution enables machine builders to simplify the integration in their machines thanks to a very consistent design. It also gives customers the opportunity to focus on their core competence and technology while ETEL provides expertise for the motion system (refer to page 8 for more details).

Direct drive expertise

Focusing strictly on direct drive technology for over 30 years, ETEL's highly skilled engineers provide customers with invaluable technical resources. ETEL commits to providing attentive customer support from the early design phase to machine commissioning.

High quality

High product quality starts with state-of-the-art development tools and thorough strict qualification procedures. All ETEL motors are manufactured in Switzerland and according to the highest quality standards.

Ease of integration

Compatibility of ETEL linear motors to a wide range of control electronics results in easy integration of a direct drive solution.

Product range

With standard motors from 72 to 704 mm in length and from 90 to 3700 N of peak force, ETEL offers one of the largest selection of ironless and ironcore linear motors on the market.

LINEAR MOTORS

During the last two decades, many linear motor variations have emerged on the market. Nevertheless, only a few were found to be practical, perform well and economically viable. ETEL has always remained dedicated to the flat, synchronous, 3-phase linear motors with permanent magnet excitation. This family of motors represents more than 90 percent of industrial applications worldwide. They can be classified into ironcore and ironless motors.

The ironcore construction enables an exceptional peak force density, as well as unparalleled thermal efficiency, which is a significant advantage for thermal-drift-sensitive precision machines. The LMA is a mid-size motor optimized for application requiring high continuous force. The LMG is smaller, optimized for high dynamic applications and provides a high peak-to-continuous force ratio. In case an upgrade is requested for an application, the LMS is highly compatible with LMG in terms of integration and provides about 30% more continuous force. This makes the LMS perfectly suited for high duty cycle axes. The ILF+ is a small size motor perfectly suited for very high dynamic and low moving mass applications. The ILM+ is a more powerful version of the ILF+. These motor types also provide a highly linear behavior, perfectly suited for the most demanding scanning applications where zero attraction force and outstanding speed stability are required.



Linear motors range

ETEL offers the most comprehensive standard linear motor range in the industry. With more than 50 models to choose from, almost any requirement can be satisfied.

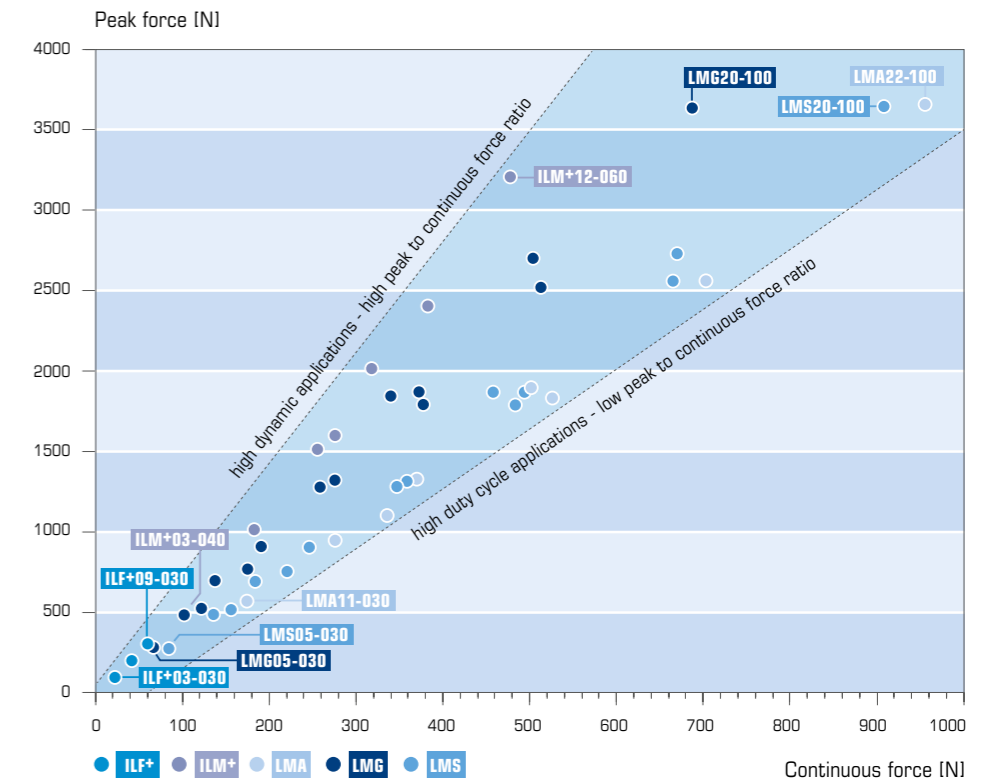

| | CHARACTERISTICS | TYPE | HIGHLIGHTS | APPLICATIONS |
|---|---|-------------|--|---|
| STANDARD PRODUCTS | <p>Ironcore motors</p> <ul style="list-style-type: none"> Speed up to 15 m/s Acceleration up to 20 g Peak force up to 3650 N Low force ripple All linear motors types work with same MWD magnetic way | LMA | <ul style="list-style-type: none"> Highest continuous force Optimized for high duty cycle application 600 VDC compliant | <ul style="list-style-type: none"> Wafer inspection systems Chip placement machines Flip-chip / die bonders Wire bonders PCB drilling PCB testing machines Flat panel display equipment Medical equipment General automation |
| | | LMG | <ul style="list-style-type: none"> Compact design Economic High peak force 600 VDC compliant | |
| | | LMS | <ul style="list-style-type: none"> Compact design Economic High continuous force 600 VDC compliant | |
| PERMANENT MAGNETS SYNCHRONOUS LINEAR MOTORS | <p>Ironless motors</p> <ul style="list-style-type: none"> Acceleration up to 30 g Peak force up to 3200 N Option: forced air cooling No attraction force No force ripple | ILF+ | <ul style="list-style-type: none"> Medium force Very low mass glider 600 VDC compliant | <ul style="list-style-type: none"> Wafer inspection systems Chip placement machines Flip-chip / die bonders Wire bonders Very high dynamic axes PCB testing machines Air bearing systems CMM measuring machines Optical equipment manufacturing Medical equipment |
| | | ILM+ | <ul style="list-style-type: none"> High force Low mass glider 600 VDC compliant | |
| INTEGRATED MOTORS | <p>ETEL motor design competences also serve more complex requests such as fully integrated axes. In fact, motors can be designed to perfectly fit a very specific form factor to satisfy customer applications. This process ultimately provides highly integrated motion systems with unique performance. Our linear motors and our expertise in direct drive technology are included into ETEL's motion systems and their dedicated components.</p> | | <ul style="list-style-type: none"> Chip placement machines Flip-chip / die bonders Wire bonders PCB testing machines Very high dynamic axes | |

Mechanical compatibility between LMG and LMS

Dimensionally, LMS motors are about 7 mm thicker than LMG versions, while all other critical dimensions remain unchanged. Mechanical interfaces are identical between corresponding products, representing an immediate "plug & play" upgrade opportunity.

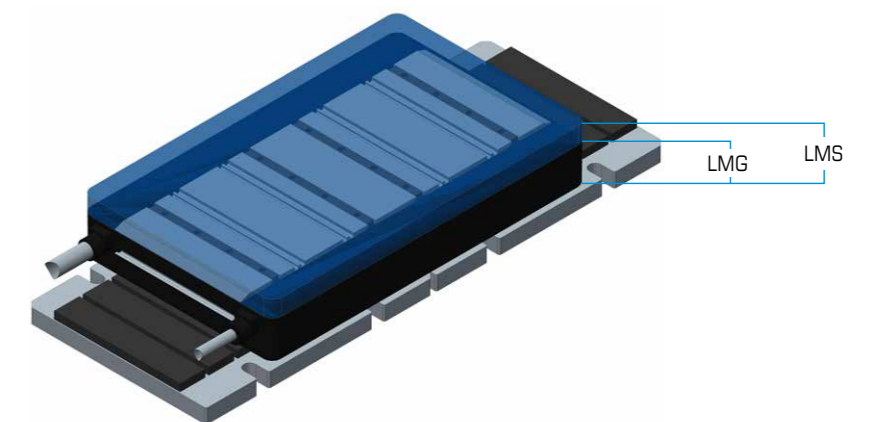

DIRECT DRIVE SOLUTION

To achieve optimum performance from a direct drive motor, it must be built to the necessary standards of precision and stiffness as part of a complete direct drive solution. In addition to the motor, the main key components of a direct drive system are the controllers, encoders, bearings and machine structure.

Controllers

The best linear motor performance is achieved when integrated with a fully digital controller with extremely high bandwidth capability like the ETEL ACCURET position controller family.

In a direct drive system, the controller can benefit from a very precise position feedback due to the fact that there is no transmission in between the feedback device and the load. Because of this high quality feedback signal, a high-end controller (such as ETEL's ACCURET) can compute advanced control algorithms at a very high frequency. Ultimately, the precision and the dynamics of the axis are drastically increased.

Some key factors to be taken into account when selecting a controller are listed below:

- High frequency control loops (current, speed, and position loops).
- High current and position loop bandwidths (typically >2 kHz and >100 Hz respectively).
- High encoder interpolation factor to ensure adequate speed and position resolution.
- Advanced control algorithms (PID with feed-forward, state space regulators, observers, notch filters, etc).
- Advanced features: ability to compensate for cogging torque, stick slip, and other system repeatable phenomena.

ETEL's linear motors have been successfully integrated with most major brands of servo controllers and CNC including: HEIDENHAIN, Siemens, Fanuc, Bosch, B&R, Kollmorgen, and Num.

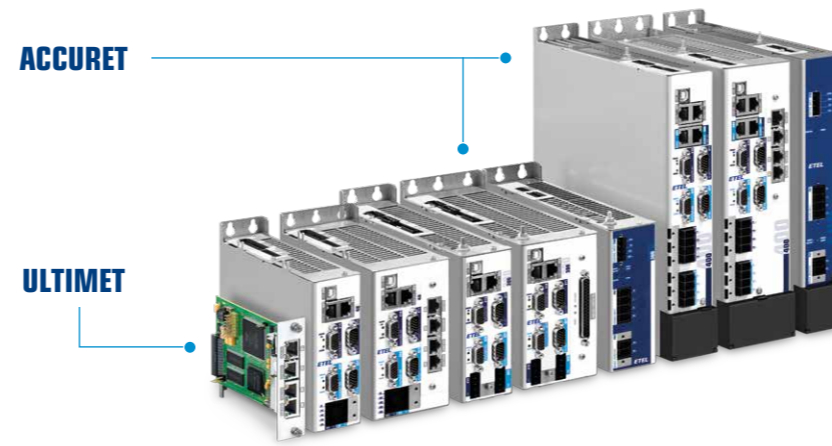

ETEL's ACCURET/ULTIMET controller family is specially designed for a variety of electronics and semiconductor related applications, where extremely high precision is needed without any compromise regarding throughput. They can provide:

- High position accuracy
- Close to zero settling time
- High dynamics
- Multi-axis interpolation
- Real-time communication bus
- And much more...



For more information, refer to our **Motion Control** catalog.

Encoders

Direct drives place rigorous demands on position-signal quality. Optimum measuring signals increase the quality of the machined workpiece surface, reduce vibration in the machine frame, stop excessive noise exposure from velocity-dependent motor acoustics, and prevent additional heat generation in the motor.

Generally, ETEL recommends the use of encoders with optical scanning methods that provide benefits in accuracy, speed stability, and thermal behavior of direct drive axes. Since there is no mechanical transmission between the encoder and the feed unit, the position encoder must have a correspondingly high resolution for precise velocity control at slow traversing speed.

A rough estimate to achieve good performance is 100 lines per pole. To achieve very high accuracy this value must be increased. Very high speed applications may require a lower line count to limit signal frequency. When combined with the interpolation capability of the electronics, resolutions of less than 1 arcsec can be achieved.



Picture courtesy of Dr J. HEIDENHAIN GmbH

Axis stiffness

Special attention must be paid to the machine's structural stiffness. In most applications the structure should be designed with a natural frequency above 200 Hz. Finite element analysis is typically used as a design validation tool.

A high performance control loop and high performance components (motors, electronics, and encoder) combined with an optimized mechanical design will lead to better system rigidity.

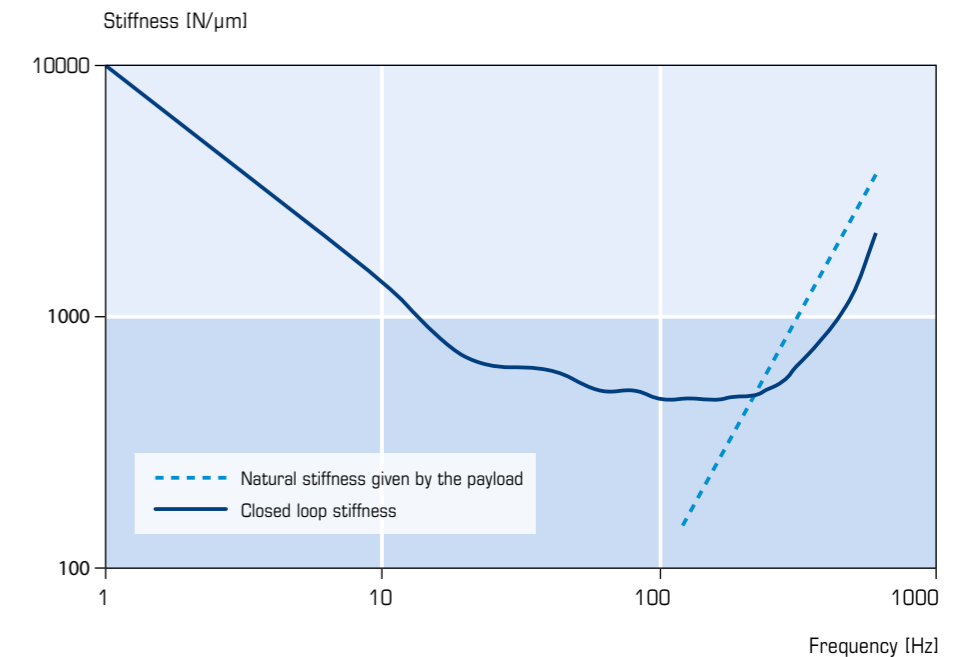
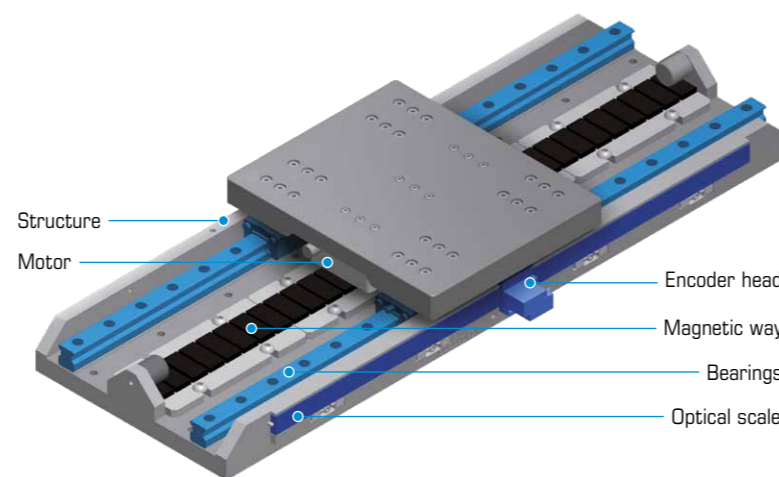

Pictures courtesy of Dr J. HEIDENHAIN GmbH

LINEAR MOTOR SELECTION

Many factors must be taken into consideration when choosing a linear motor to ensure outstanding system performance. This brochure provides a basic overview of some of the key selection factors that should be taken into account when choosing a linear motor. For detailed calculation and sizing information, please refer to the ETEL linear motors handbook, or ask an ETEL application and support engineer for assistance.

Motor sizing

The first step in a linear motor sizing is to define the force and motion requirements for the application. The maximum required acceleration and the payload mass are used to determine the peak force. The force required for each move within the cycle can then be used to determine the continuous force. The amount of heat produced by motor power dissipation will determine the temperature increase of the structure. Power dissipation is estimated by calculating the continuous force and all additional sources of force such as friction, machining force, static force due to an offset load and external perturbations.

Under static conditions with an applied load, one motor phase can get disproportionately hot, because the power dissipation is not shared equally among all three phases. To ensure smooth operation under these conditions a stall force calculation should be performed. In rare cases, the detent force may impact speed stability, especially if the position control regulation bandwidth is limited. ETEL's position controllers provide the ability to compensate the detent force for high accuracy applications.

ETEL's motors are available in several winding configurations. The winding should be chosen to match the speed requirements of the application as well as the voltage and current specifications of the electronics. Note that the force/speed characteristic of a motor changes with the winding.

Detent effects

Thanks to a patented design, ETEL has the expertise to manufacture ironcore linear motors with very low detent effects. The patented design uses an innovative combination of open slots, orthocyclic windings and fractional pole pitch. This solution significantly reduces detent effects without any skewing of laminations or magnets which would result in lower force density. Furthermore, detent effects at the motor extremities are eliminated by the use of specially-shaped teeth.

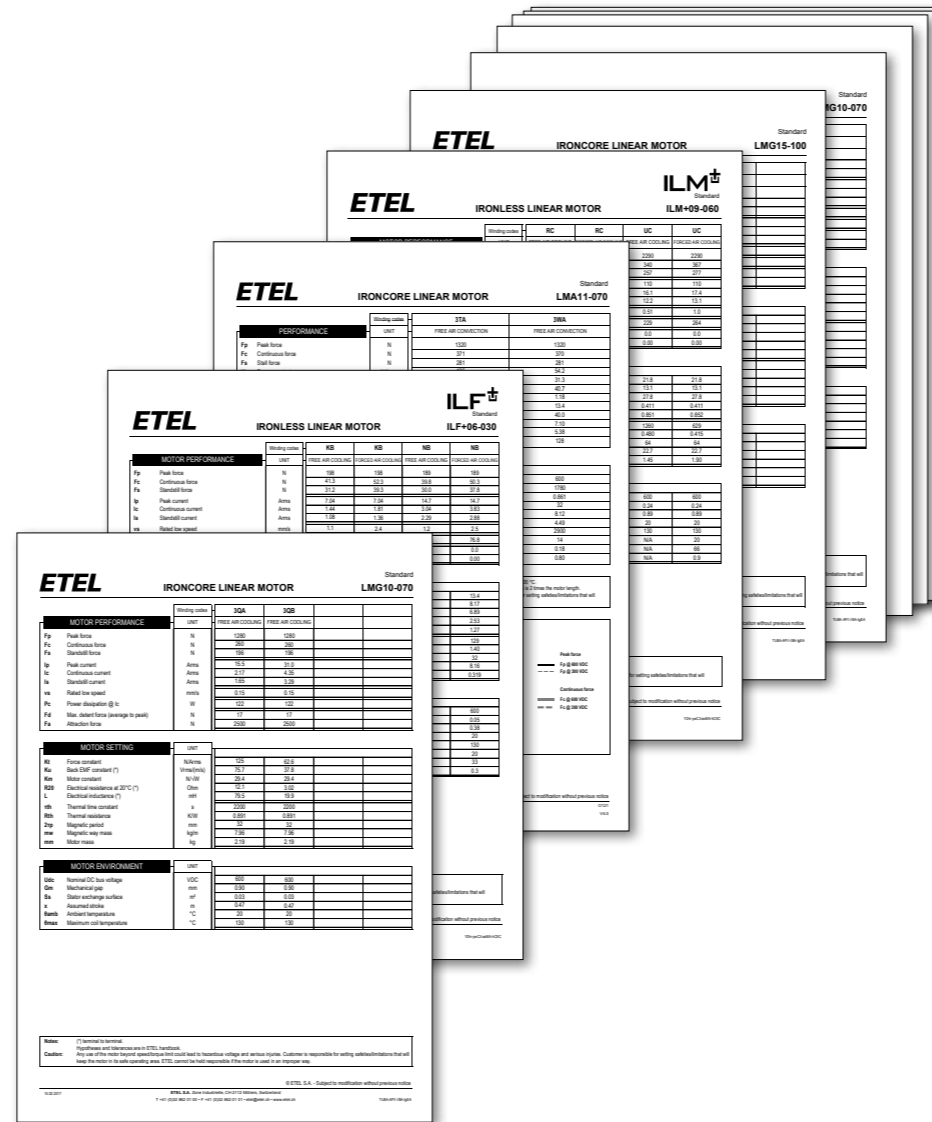

Motor constant

The motor constant, K_m , is one of the key parameters for comparing permanent magnet synchronous motors relative efficiency. It shows the relationship between force produced and resulting power losses. A motor with a higher value of K_m is a more efficient generator of force. K_m is determined by the design and construction of the motor. This parameter is related to the internal design of the motor (copper filling factor, electromagnetic design, etc). Therefore, it is a better indicator of motor performance than the force constant, K_t (Nm/Arms), which relates force output to the supplied current. K_t is easily adjusted by changing the wire gauge in the winding. K_t is useful for matching a motor to a servo amplifier, but it does not provide information about the motor's efficiency. Thanks to a patented design, ETEL is able to significantly increase the packing efficiency of ironcore linear motors' slots (increase in K_t) and to decrease the amount of copper wire extending beyond the slots (reduction of ohmic loss). Moreover, it leads to an important increase in continuous thrust and better thermal behavior (resulting in an improved K_m).

Thermal considerations

The performance of the motors as well as the overall machine behavior are closely related to heat transfer. As with any other kind of electrical motor, heat is generated during operations. Unless it is removed by an efficient cooling system, this heat will be transferred to the machine structure and the motor's surroundings. Depending on the application (precision required, dynamics, duty cycle) heat could prevent the machine from reaching its specifications. Thus it has to be taken into account in the early design phase. To help in selecting the right motor and getting the best machine performance, ETEL defines in its motors' data sheets an assumed exchange surface for each motor type. It represents the surface to which the motor is mounted for optimal heat transfer. This value is very important and closely related to the motors continuous force (F_c). However, once mounted in the machine, the exchange surface will most likely be different. Two scenarios can occur:

- The real machine exchange surface is larger than the assumed one. Then the motor performance can be increased. Higher continuous force or less heat at a given duty cycle can be obtained.
- The real machine exchange surface is smaller than the assumed one. This is the case, for example, when a thermally insulating layer is added in between the motor and the carriage. In this case, thermal transfer is limited as well as motor performance.

Do not hesitate to contact your ETEL's representative for technical support during machine design phase.

Data sheets

ETEL linear motors information is available in the corresponding ironcore and ironless motors data sheets. These include the specifications, performance as well as the force vs. speed curves of each standard ETEL motor. For more information about the linear motors or to download the data sheets, refer to our website: www.etel.ch



Integration manual

For more information on motor selection and integration, ask for the ETEL linear motors integration manual through the request form on our website or contact your corresponding ETEL representative.



ETEL sizing tool

ETEL has developed a powerful sizing tool which simulates the customers' machine operation. It helps in achieving the very best "performance/price" ratio that can be obtained on your specific application. Do not hesitate to contact your ETEL representative for technical support during the machine design phase.



CASE STUDIES

ETEL linear motors in CMM machines



Metrology machines are among the final steps of a manufacturing process which ensure that the final workpiece is under the proper specifications for mass production. Coordinate measuring machines (CMM) are used as part of this process by using a measuring probe moving through X-Y-Z planes to take points along a workpiece surface in order to properly measure any deviations for the desired specifications. As the tolerance standards for

machine parts increase along with the complexity of the workpieces, CMM's have been dealing with increasing demands requiring greater levels of precision.

ETEL's LMS and LMG linear motor series have been used on some of the industries' first CMMs utilizing direct drives. This allows them to maintain the proper submicron levels of precision needed for many industries while still allowing for an increase in throughput due to the reduced downtime. For CMM's, the most valuable aspect of direct drive linear motors is its ability to provide the necessary precision without any wear components. Unlike conventional machines based on belts and pulleys, CMMs machines operate at peak performance for many years of use just as if they started operations the day before.



Picture courtesy of Advance Industrial Measurement Systems (AIMS)

ETEL linear motors in AOI systems



In many manufacturing processes, inspection is a crucial step to ensure final product functionality and reliability. ETEL is present in a wide range of Automated Optical Inspection (AOI) systems providing high precision and maximized throughput by using direct drive linear motors. For instance, in PCB inspection units targeting line space below 15 microns, a combination of high performance optics and of motion system is necessary to maximize yield. In case of IC substrate inspection, the structures to be controlled reduce to a few microns in size for substrates typically used in chip-scale or ball grid array packages.

Moreover, the precision required has to be ensured over a wide surface without any compromise to performance or machine throughput. A precise point-to-point motion with extremely short in-position-time is made possible by using ETEL direct drive technology.

Thanks to the ETEL LMG series of ironcore linear motors, one can safely design flexible machines that achieve exceptional detection sensitivities in a wide range of AOI tasks. The high force density of ETEL motors allows a very compact design that helps maximize the working area, as well as increasing the overall machine throughput. In addition, quality and reliability are two of the many key points that customers benefit from using ETEL products to ensure a stable, maintenance-free and very long machine lifetime. Finally the extended range of standard LMG motors makes machine development roadmap easier by providing a stable motion system design to continuously meet the evolving specifications.



Pictures courtesy of Camtek Ltd.

ETEL product range in flying probe tester machines

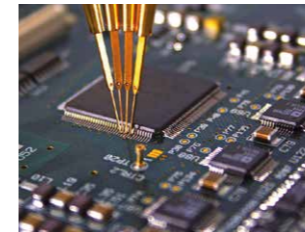

ETEL has been present in the electronics industry since many years providing the best performing motion control solutions. In flying probe tester machines, throughput and precision are key factors to success. Nowadays, machines equipped with ETEL's LMG motors provide the highest throughput on the market without any compromise on precision. The main axes of the illustrated machine are driven by ETEL's LMG motors, allowing extremely high speed dual-sided probing with a motion resolution of less than 20 nm. ETEL's standard ironcore linear motors together with an optimized machine design contribute to make these flying probe tester machines a point of reference on the market.

In this case, the fast and precise motion control of up to 24 axes is ensured by ETEL position and motion controllers. The optimal fit between ETEL motors and motion controllers, as well as the advanced features provided by ETEL controllers, provide outstanding performance in such applications.

Additionally, the 15 g Z-axis motion of the testing probe is provided by a unique custom motor design developed in synergy with our customer. This unique and fully integrated Z-axis design is made to exactly fit the application needs maximizing performance and reducing costs of ownership.

Finally, this ETEL based direct driven machine is able to achieve outstanding probing accuracy and throughput values. Such performance would be impossible to reach with other types of motion technologies like reluctant planar motors or rotary based systems.



Pictures courtesy of SPEA Spa

ETEL product range in wire bonding applications

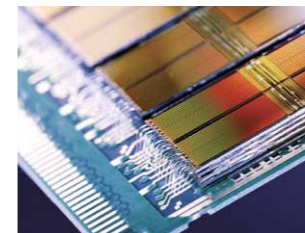

ETEL is present in the majority of the critical stages during the IC manufacturing process. From the very early lithography process to the final pick and place machines, ETEL provides the best suited direct drive motors to fulfill highly demanding applications. Wire bonding is one of these important processes of semiconductor device fabrication where ETEL is strongly present to help our customers reach outstanding machine performance.

Many variants of wire bonding exist and might lead to slightly different key specifications when designing the motion system. However, speed, precision, and reliability are in any case the most important requirements. Many leading companies in the wire bonding industry use ETEL solutions to reach unmatched performance levels.

The very wide range of ETEL linear motors and controllers provides a solution to perfectly fit the most demanding requirement of such high-end machines. On one hand, the use of ETEL ironless motors provides low moving mass for very high dynamic axes, to finally obtain the fastest bonder in this market segment. On the other hand, ironcore motors are also used to maximize the force density and thus to reach the largest possible bonding area in a given volume. By using ETEL ACCURET controllers and some of the most advanced features currently available on the motion control market, one can reach extreme precision levels in the micro meter range without any compromise of the machine throughput.



Pictures courtesy of Hesse GmbH

ETEL'S LINEAR MOTORS IN HIGH-END MOTION PLATFORMS

ETEL technology in wafer inspection motion systems

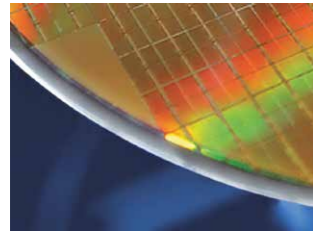

Linear motor technology is also a key performance enabler for semiconductor applications of advanced motion solutions. Today, serving current and future needs of advanced solid-state electronics manufacturers, means mastering positioning challenges at nanometer level. When the tolerable error budget is a small fraction of the gate length and dynamics need to sustain continuous throughput enhancement, ETEL motion solutions spark and guarantee customers' peace of mind with record proven reliability. With its ability to deliver complete turnkey solutions, of which linear motors are a core component, ETEL brings unique value propositions at reduced time-to-market and improved cost of ownership. Whether deployed in process or in process control equipment, ETEL's solutions, based

on LMG linear motors driven by ULTIMET controllers, embedding the most advanced and sophisticated features, deliver best in class performances, highly customizable by integrators and with no compromise on ease of use.

A bright example of typical requirements, and of delivered performance, comes with the following solution. With 7 degrees of freedom, it runs at 2.5g acceleration and 1.5 m/s speed, while guaranteeing less than 5nm jitter at tool point. With best in class cost per achieved performance, standardized footprint and plug & play integration, it helped many chip manufacturers to continue following their aggressive roadmaps and market demands.

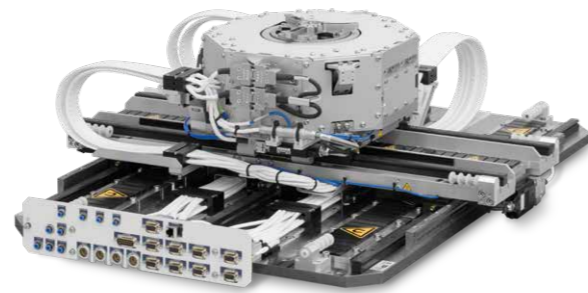

ETEL XYZ3Tth nanometer motion system for wafer inspection

ETEL technology in the semiconductor industry

The semiconductor industry is well known to have implemented, very often defined, some of the most stringent quality standards; these are implemented through high density and high volume sampling of products during the entire manufacturing cycle, starting from incoming inspection of substrates until testing of the encapsulated device. Many different techniques are used to accomplish the task, preferably by means of non-destructive testing, ideally by complementary technologies aiming to increase the amount of controlled parameters, providing much richer data and better data quality. Thanks to its presence in the entire supply chain, ETEL has developed a unique expertise in understanding end users' needs. Complex relationships existing between a given technique and the motion characteristics necessary to maximize its performance. ETEL masters such space and leads the market by constantly researching new and better solutions, and it engineers products fulfilling the most stringent requirements at all levels,

starting from motors. The result of this are complete motion solutions which embrace a very broad range of use cases, spanning from the high accuracy needs of FEOL to the large payloads of BEOL.

An example is the following product which, associated to sub-Newton force control, allows to rapidly and gently place delicate tips in contact with the electrical pins of the chip and control the device characteristics. This solution can move a mass of 2 kg at 1 g acceleration and 1 m/s speed with a final repeatability below 1 µm.

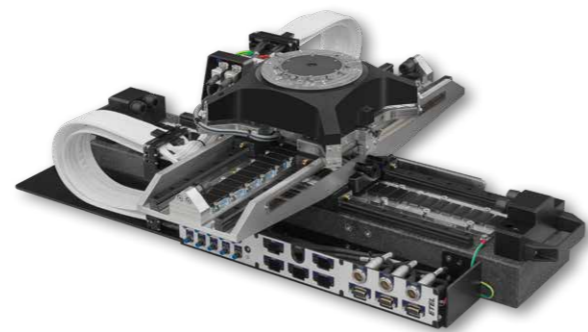

ETEL CHARON2 XYT

ETEL specific motor design in short stroke actuators



ETEL short stroke actuators for IC testing handlers

In many different industries, highly integrated actuators are requested. In such cases where the form factor is the most critical specification of the motion system, it might happen that conventional linear motors cannot fulfill the application needs. In this case, ETEL motor experts are able to provide a motor design with the best performance to volume ratio.

ETEL develops a wide range of short stroke actuators to address diversified needs in applications such as: pick & place, IC testing, flying probe testing, etc. In each of these applications, the form factor is of major importance to fit a high-end direct driven axis in the machine environment. The motors are designed around specific requirements and integrated together with bearings and feedback devices in the most suitable form factor. This deep integration process leads to a cost effective and high performance solution that fits to the exact needs of the targeted process.

ETEL short stroke actuators can be based on different motor technologies depending on the motion requirements. In such products, ETEL mainly uses miniaturized single phase ironcore motors as well as single phase moving magnets or voice coil type motors. Ultimately, one can achieve extremely high dynamics (up to 30 g acceleration) together with a micrometer precision level thanks to linear optical encoders. These very small and light actuators can operate maintenance free for billions of cycles with an extremely high throughput. ETEL's uniqueness is to merge compactness, performance, and reliability to achieve what can certainly not be achieved by combining conventional technologies.



Combining ETEL short stroke actuators with RTMBi for accurate turret handlers

Most of the time, high-end applications in the semiconductor industry integrate complex equipment set-up, which, in one way or another, is connected to the granite of the motion platform. Some of those applications have stringent position stability requirements at the stage level, down to the nanometer range! Any vibration at the granite level therefore translates into inaccuracies and longer settling times at the process tool level.

The QUIET active isolation system is a new module cancelling both stage-born and ground-born vibrations along 6 Degrees Of Freedom (6 DOF), preventing them from perturbing the process taking place on top of your motion platform. This is done through specifically designed linear motors, providing high force density over very short stroke of a few microns.

Coupled to a proprietary low-noise sensor and an homogeneous, fully digital, and deterministic motion control architecture based on 1 Gb TRANSNET, QUIET reduces move and settle times to unprecedented values. With an acceleration feedforward accuracy reaching higher than 99%, less than 1% of the energy generated by a motion stage movement remains at the granite level! The mass of the granite on the active isolation system can therefore be kept small, which in turn reduces the overall real estate and mass, while processing tools directly benefit from a quieter environment.

Thanks to the QUIET product from ETEL, getting rid of those vibrations has never been done so efficiently!

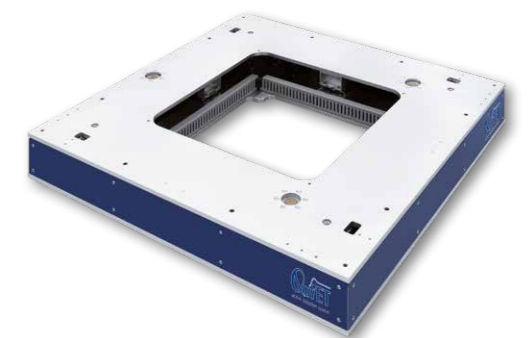

ETEL Active Isolation System QUIET



HEADQUARTERS

ETEL S.A.

Zone Industrielle
CH - 2112 Môtiers
Switzerland

T +41 (0)32 862 01 00
F +41 (0)32 862 01 01
etel@etel.ch · www.etel.ch

GROUP SUBSIDIARIES AND SALES OFFICES

AMERICAS • info@heidenhain.com

BELGIUM • sales@heidenhain.be

CHINA • sales@heidenhain.com.cn

CZECH REPUBLIC • heidenhain@heidenhain.cz

FRANCE • sales@heidenhain.fr

GERMANY • tbsw.etel@heidenhain.de

GREAT BRITAIN • sales@heidenhain.co.uk

ITALY • info@heidenhain.it

JAPAN • sales@heidenhain.co.jp

KOREA • etelsales@heidenhain.co.kr

SCANDINAVIA • sales@heidenhain.se

SINGAPORE • info@heidenhain.com.sg

SWITZERLAND • verkauf@heidenhain.ch

TAIWAN • info@heidenhain.tw

THE NETHERLANDS • verkoop@heidenhain.nl

OTHER COUNTRIES • internationalsales@etel.ch

REPRESENTATIVES

ISRAEL • comotech@medital.co.il

SPAIN • farresa@farresa.es

ETEL